

## Tape and Reel

The quantity per reel is shown in Table 1. If not specified by the customer, quantities will be determined by Discera in the most efficient manner based on existing factory conditions.

Package (QFN)	Quantity 7" reel	Quantity 13" reel
7.0x5.0 mm	1000	3000

Table 1.

## Reel Specifications

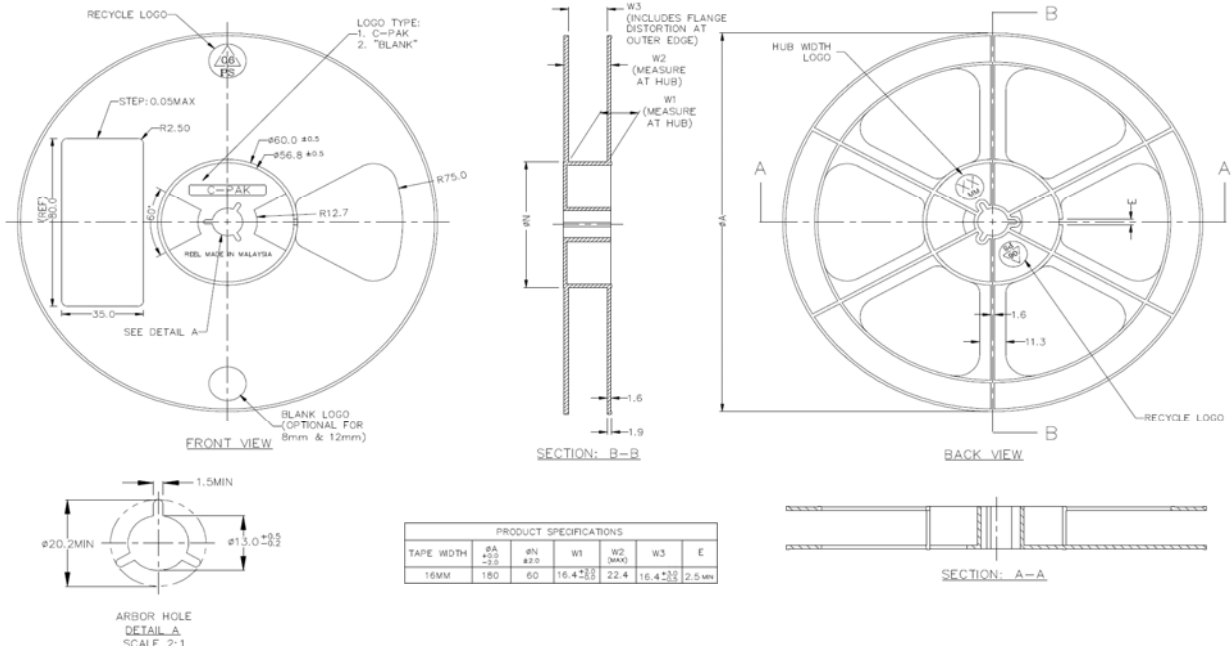

Figure 1: 7" Reel

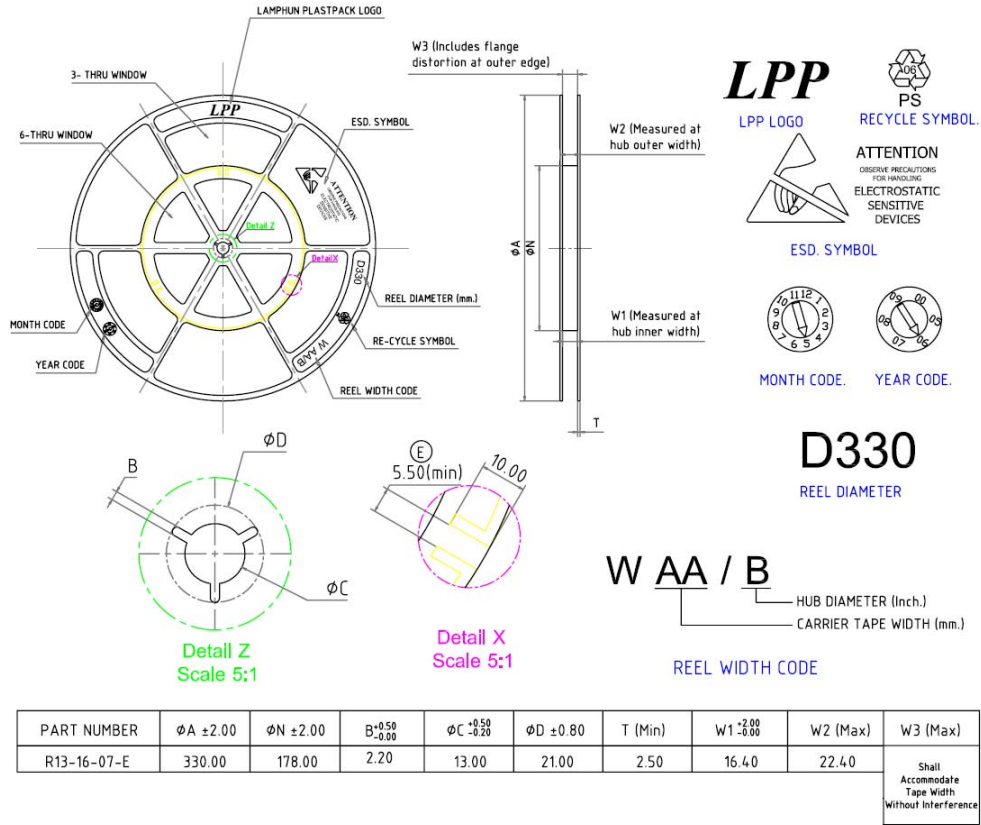

Figure 2: 13" Reel

## Carrier Tape

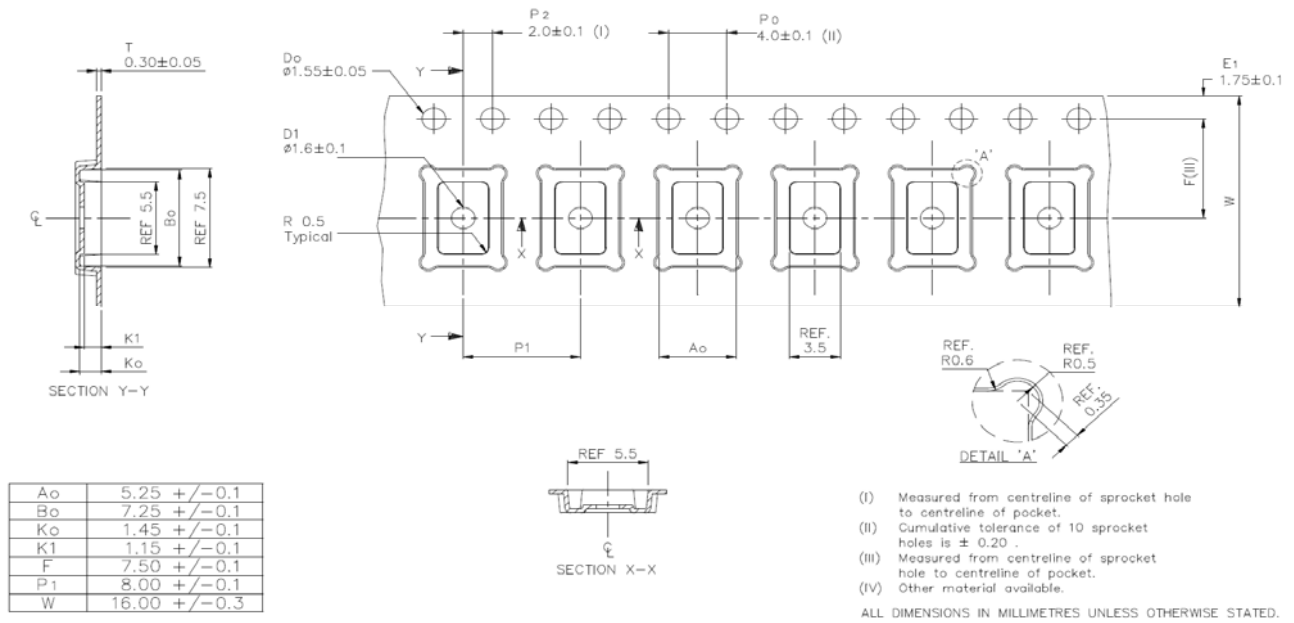

Figure 3. Embossed Carrier Tape

## Orientation

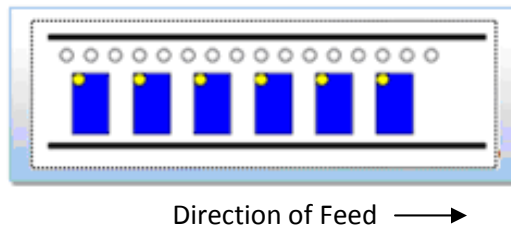

Figure 4. Orientation of unit in pocket.

## Leader and Trailer

Reel size	Empty pocket at leader	Empty pocket at trailer
7" dia	$\geq 50$ cm	$\geq 15$ cm
13" dia	$\geq 100$ cm	$\geq 50$ cm

Table 2. Leader / Trailer length